

---

# Lecture 9:

# Multipliers

Computer Systems Laboratory

Stanford University

horowitz@stanford.edu

Copyright © 2001 Mark Horowitz

# Overview

---

## Reading

## Introduction

There are tons of papers written on multiplication. Unfortunately it is rare that the paper talks about the logic and circuit issues together. There are many 'logic' papers which describe clever ways of adding the partial products, but they rarely address the cost of the wiring. Other circuit papers talk about fast ways to build the basic adder cells. We will start with the multiplier organization, and look at both the logic and circuit issues.

# Multiplication

---

Basic idea is pretty simple

- $A * B = C$

Done by generating a number of partial products, and adding them together:

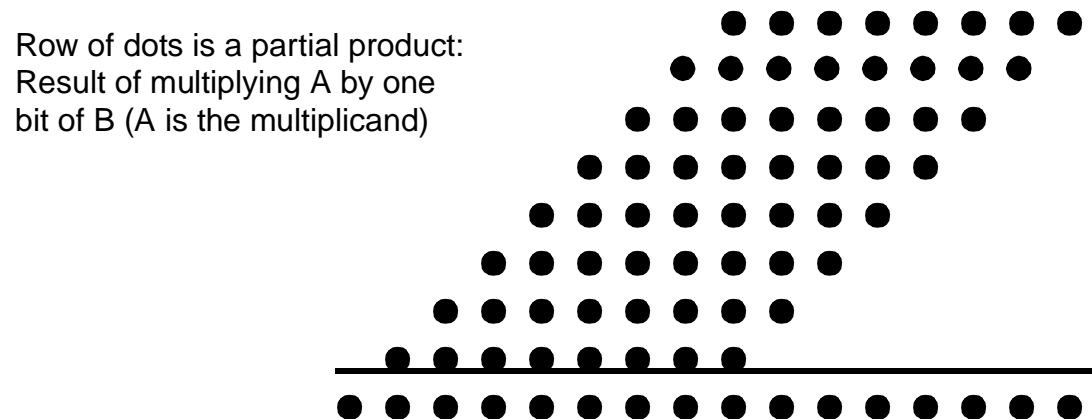

- Result is  $2n$  bits
- For integer operations want LSB  $n$  bits, for FP want MSB

FP  $1.XXXX * 1.XXX$

# Simple Multiplier

---

Takes n cycles, and generates and adds one partial product each cycles:

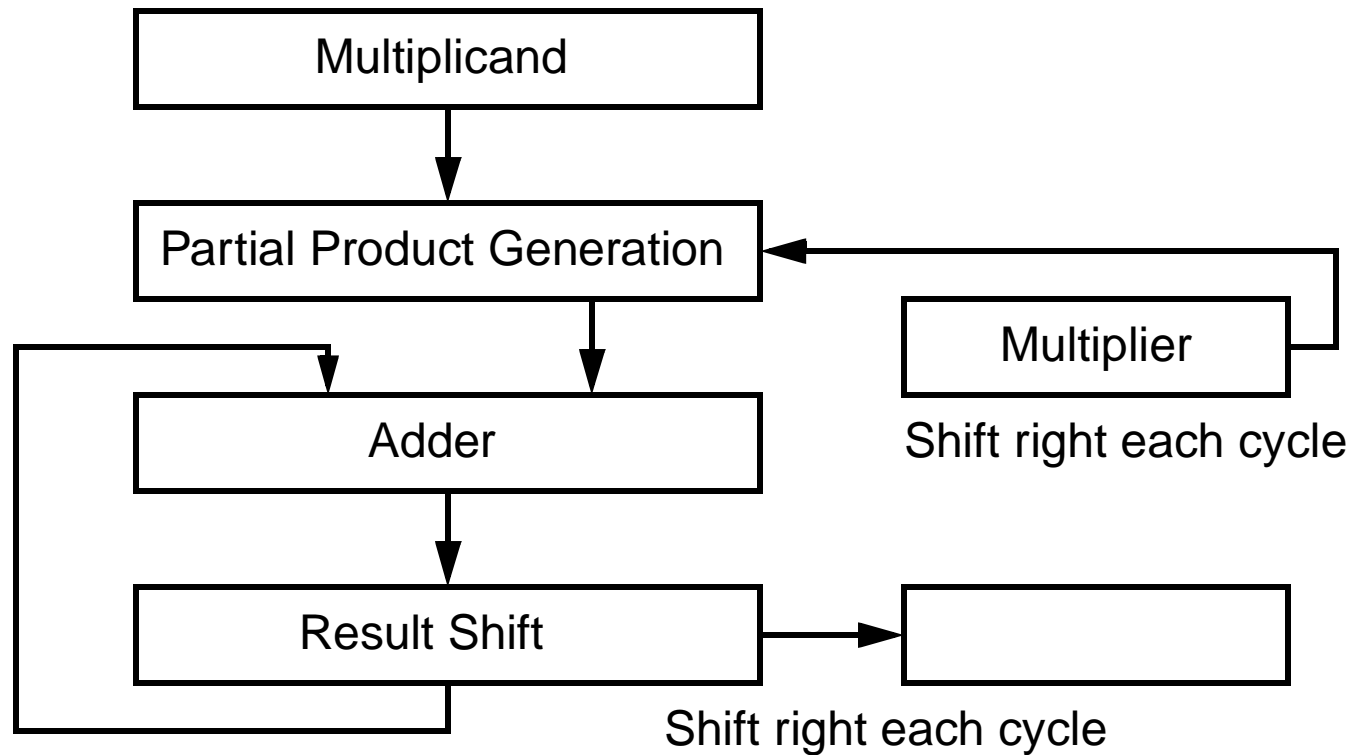

# Main Issues

---

1. Create the partial products
2. Sum them together

For a fast multiplier

- Reduce the number of partial products
- Fast Adder cells
- Tree adders

Talk about this stuff next

# Partial Product Generation

---

In the simple form it is very easy:

$$0 * A = 0$$

$$1 * A = A$$

- This is a simple AND gate at each bit
- But generate a PP for each multiplier bit

We can generate a PP for every two multiplier bits

$$00 \quad 0$$

$$01 \quad 1^*$$

$$10 \quad 2^* \text{ (this is easy to generate by a shift)}$$

$$11 \quad 3^* \text{ (yech -- but can make easy 4 -1, and delay the 4 into the next group)}$$

# Modified Booth Coding

---

Make it easy

- When the MSB of the 2bits is 1 add 4 to next group up ( $2 = 4 - 2$ )
- Booth recoder looks at 3 bits
  - The two bits it is recoding, and the MSB of previous group

Table 1:

MSB	LSB	Prev	Out
0	0	0	0
0	0	1	1
0	1	0	1
0	1	1	2
1	0	0	-2
1	0	1	-1
1	1	0	-1
1	1	1	0

# Booth Encoder

For domino circuits

- Outputs are one hot
- Can be done in one 'gate'
- Need large output buffers to drive long wire to control all the mux that are connected to it.

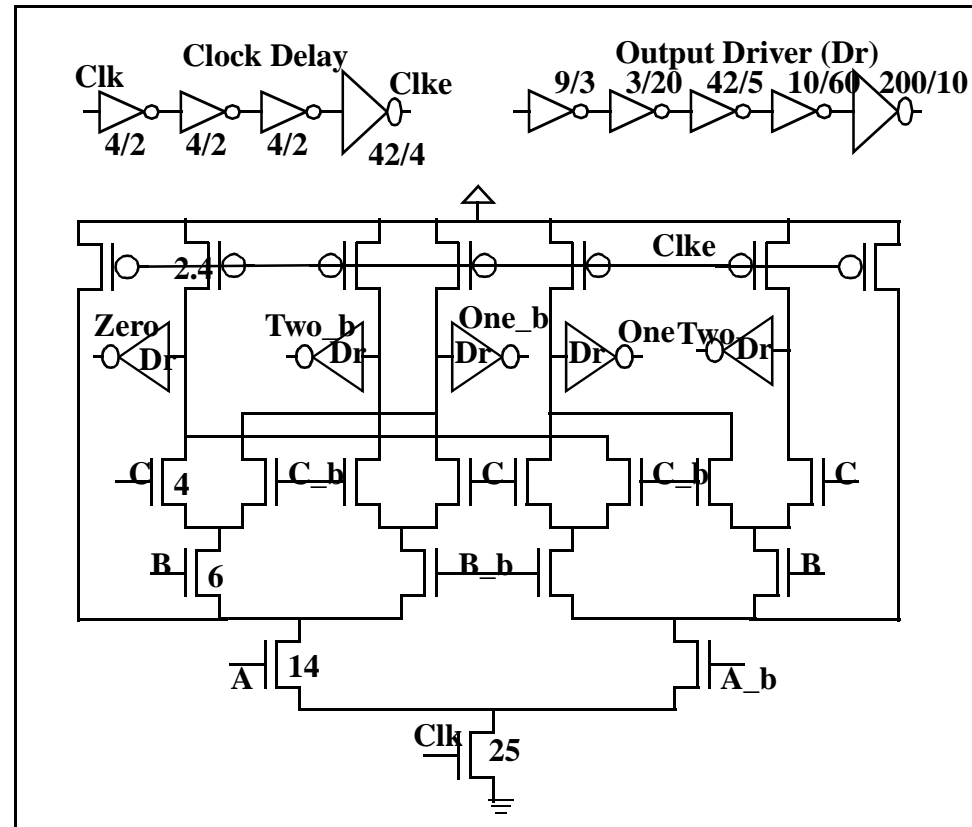

# Booth Mux

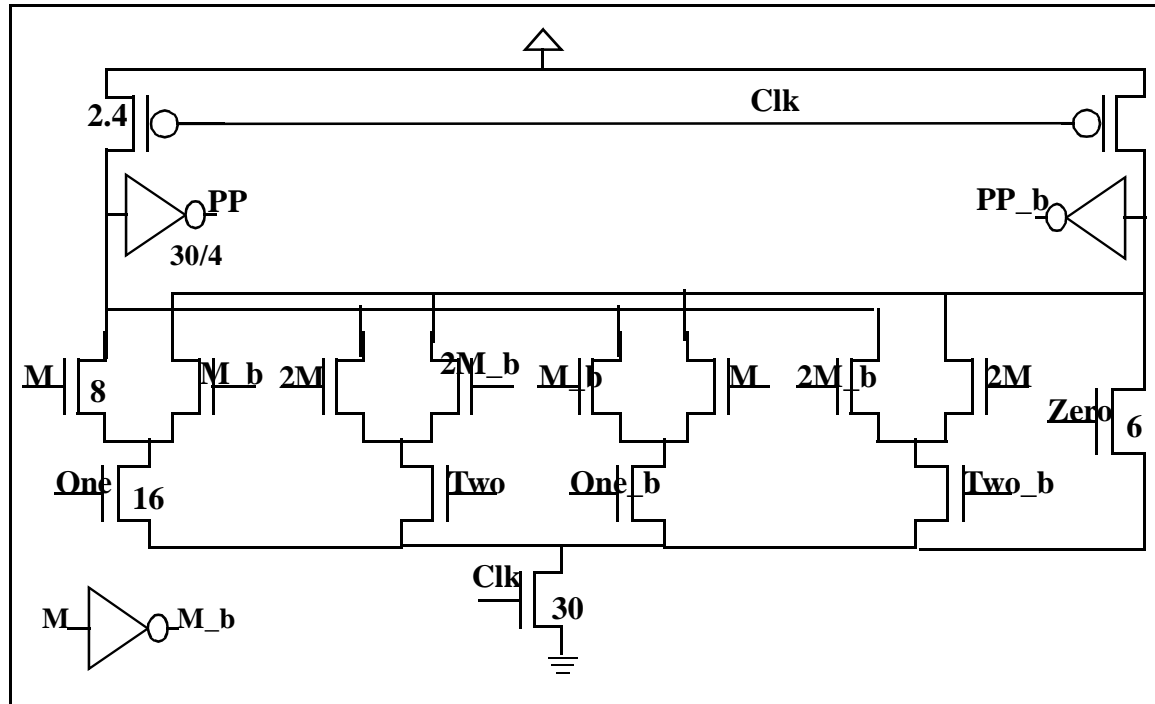

- Multiplicand is converted into dual rail partial products again by using local inverters, and is sent down to one significance higher booth mux, generating 2M.
- The adders get monotonic dual rail partial products from the booth mux.

# 3 Bit Booth

---

Can recode 3 multiplier bits at a time

- Generates 1/3 of the partial products
- But you end up with needing 3\*Multipliocand

This takes an adder

So this is generally not done

Table 2:

MSB		LSB	Out
0	0	0	0x
0	0	1	1x
0	1	0	2x
0	1	1	3x
1	0	0	-4x
1	0	1	-3x
1	1	0	-2x
1	1	1	-1x

Need to look at MSB of previous group and add 1 if it is 1. This still keeps the numbers between -4 and 4. The only hard one to generate is 3x

# Adding Partial Products

---

If you want to add more partial products in a cycle you could use multiple adders

This solution has two problems:

- Even fast adders are pretty slow  
7+ FO4 delays
- Fast adders are pretty large  
Expensive in area

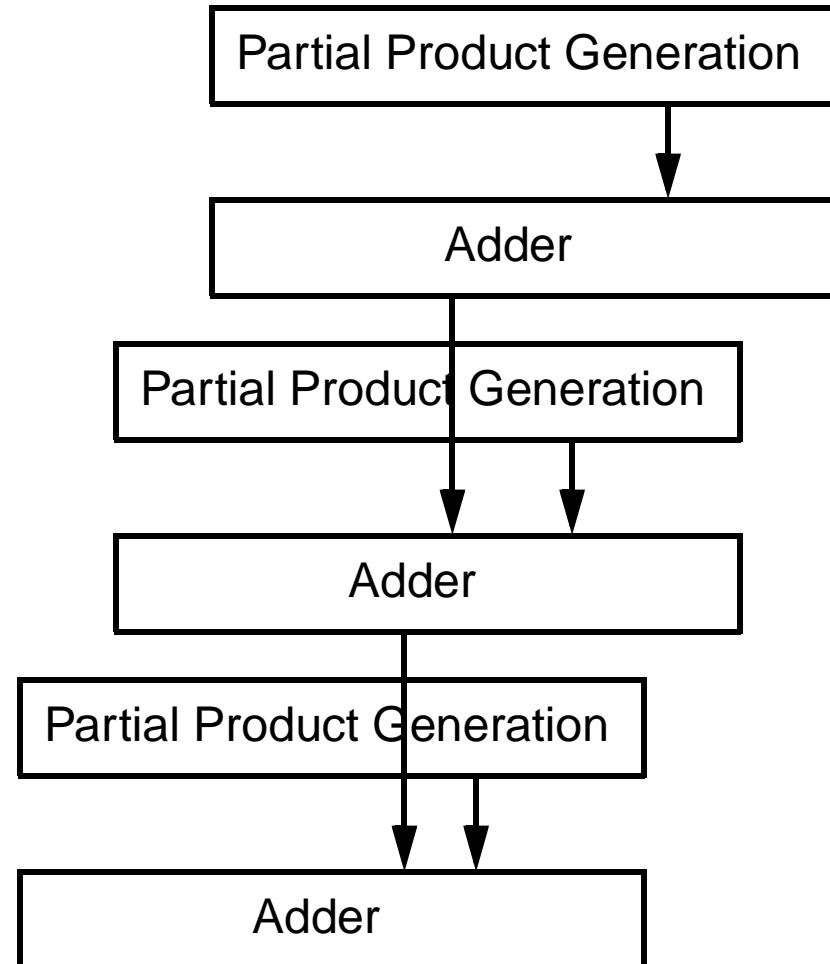

# Carry Save Adder

---

To get a faster adder we will use a trick:

- Represent the result of adder (sum) in a redundant form

$$\text{Sum} = \text{Sum}_1 + \text{Sum}_2$$

That is when you add  $\text{Sum}_1$  and  $\text{Sum}_2$  together you get the right result. This is nice since we now don't need to propagate the carry in the adder.

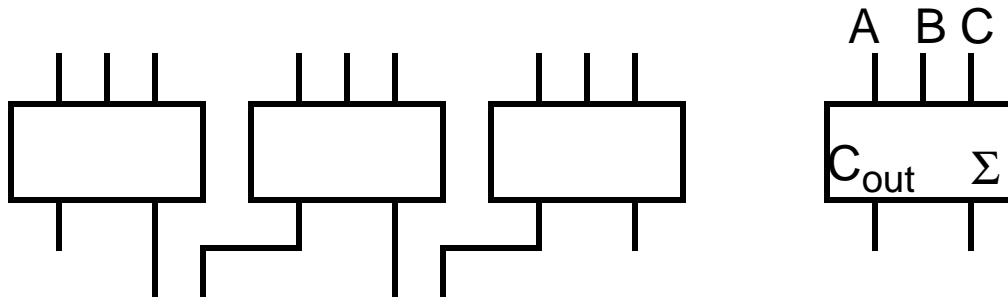

Instead of rippling the carry, shift it left by one, and use it as the 'other' part of the sum. Each stage of the adder takes 3 inputs, and produces two outputs.

# Carry Save Adder

---

Each adder can add one partial product to a redundant sum

- Redundant sum takes two inputs, partial product takes the third

Each adder is small and fast

- Domino CSA is around 1.5 FO
- CSA is pretty simple, it is just a full adder

The problem is the output is really in an unusable form

- At the end of the array you need to add two parts of redundant number together
- This take a fast adder, but you only need one at the end of multiplier, not one for each partial product

# Multiplier Overview

Block diagram of multiplier:

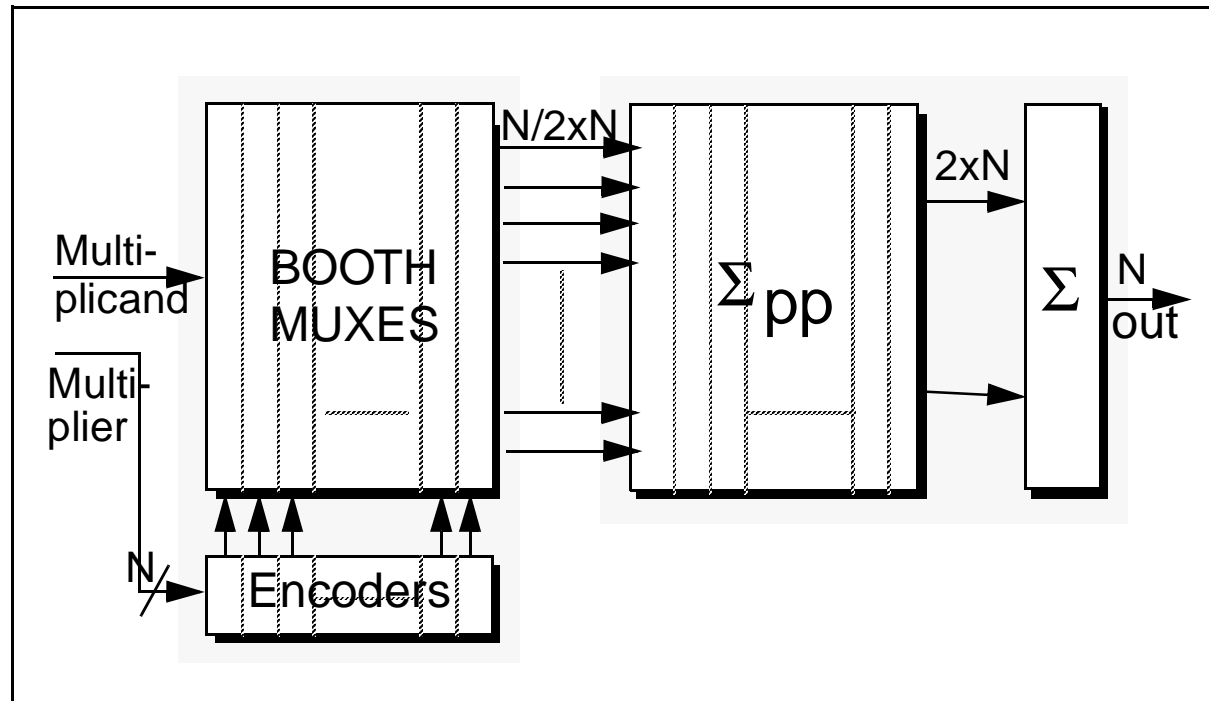

The  $\Sigma$  array is in carry save adders, and final sum is a normal adder

# Array Multiplier

For floating point numbers you have 53 bit numbers, which give 27PP

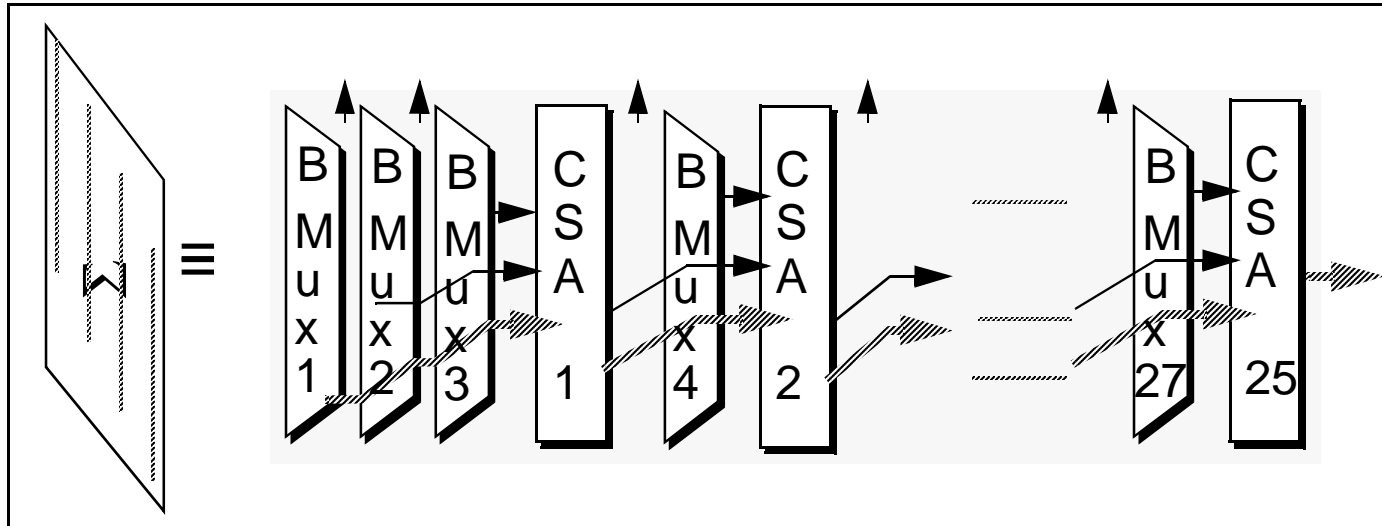

- 25 CSAs in datapath, all in critical path (First adder adds 3 PP)
- 56 bits tall regular datapath
- Short wires

# Tree Multipliers

---

Can build faster  $\Sigma$  arrays but using tree adder

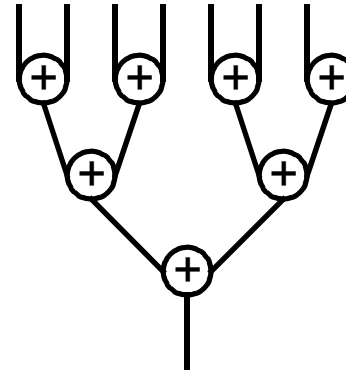
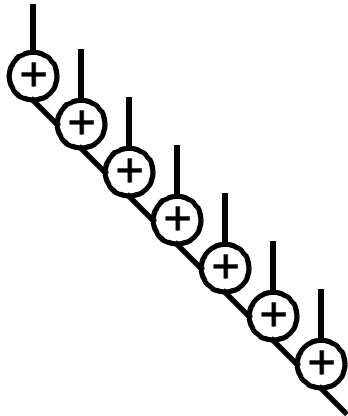

Need to be careful since:

- Trees have longer wires (each adder is a row of adders)
- Drawn a binary tree, but CSA are 3 input 2 output devices

Can build a 4:2 combiner using 2 CSA

# 4-2 Adder

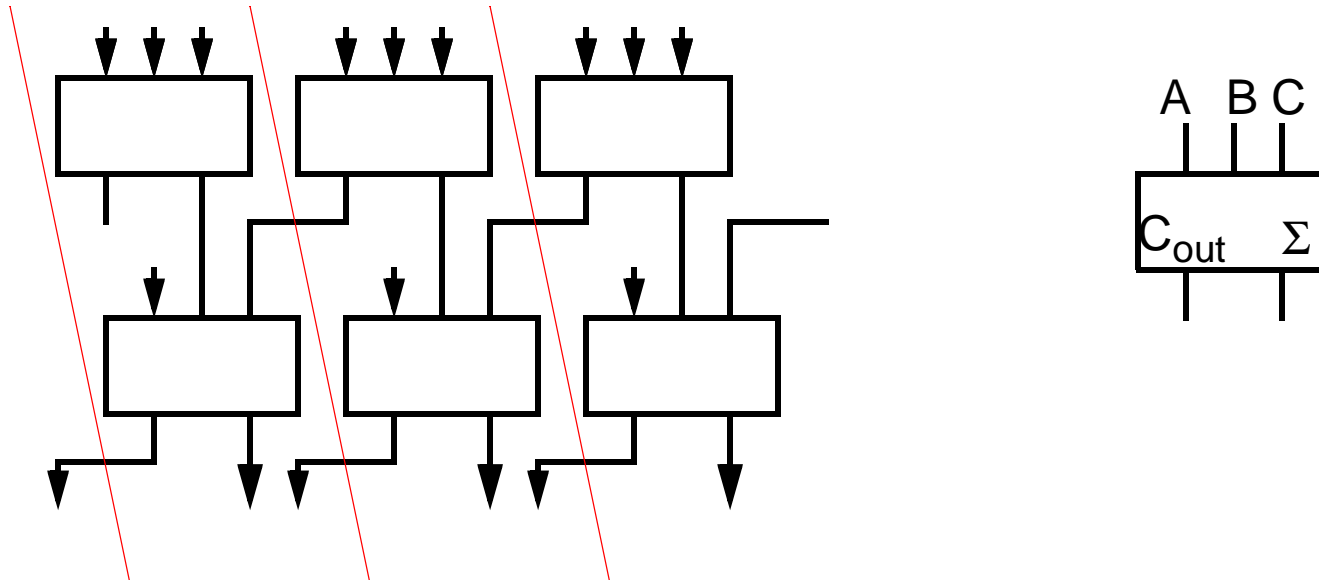

If you ignore the side branches you get 4 inputs in each bit position, and two output at each bit position. This allows you to build binary trees. You can build 3:2 trees, Wallace Trees, (and it is a little faster) but the wiring is much more complex

# Tree Layout

Full (4:2) Trees:

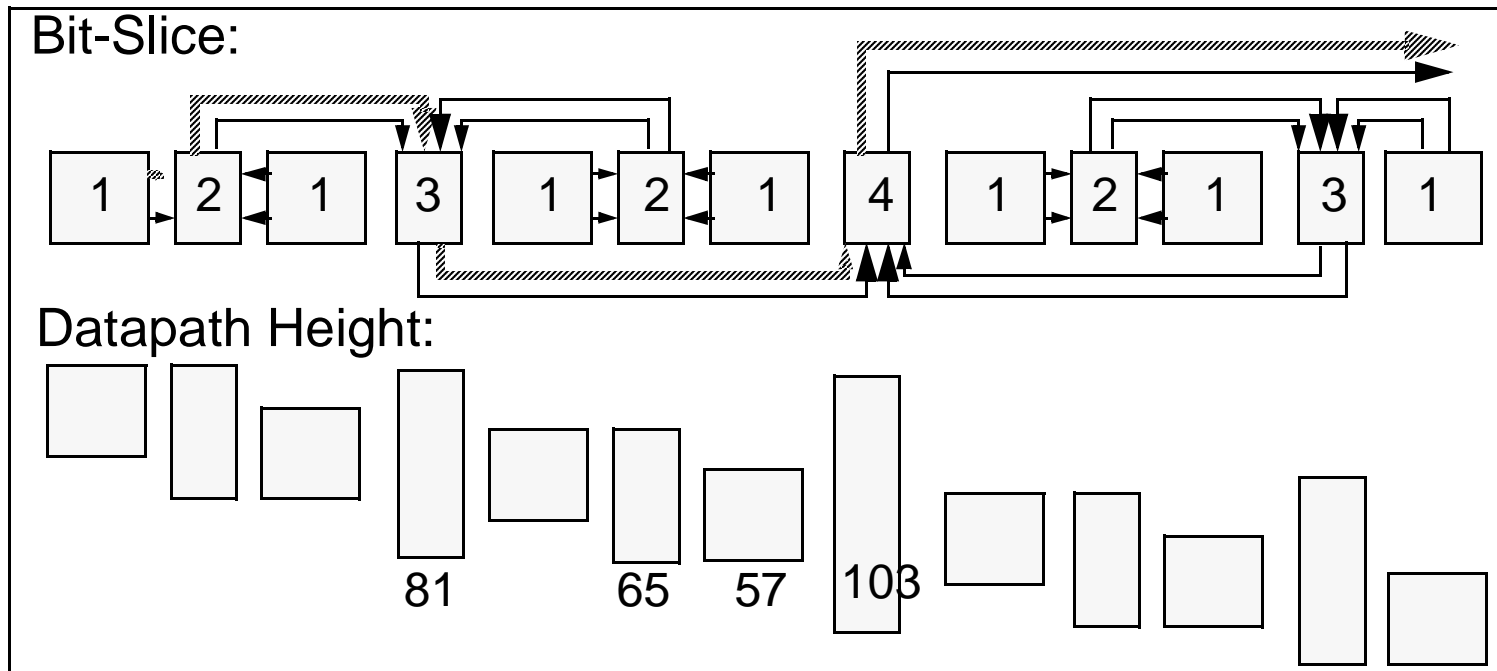

- 26 CSAs in datapath, 8 in critical path
- Increased datapath height
- Long wires, many cross-overs, wiring channels

# Interleaved Arrays

Compromise solution

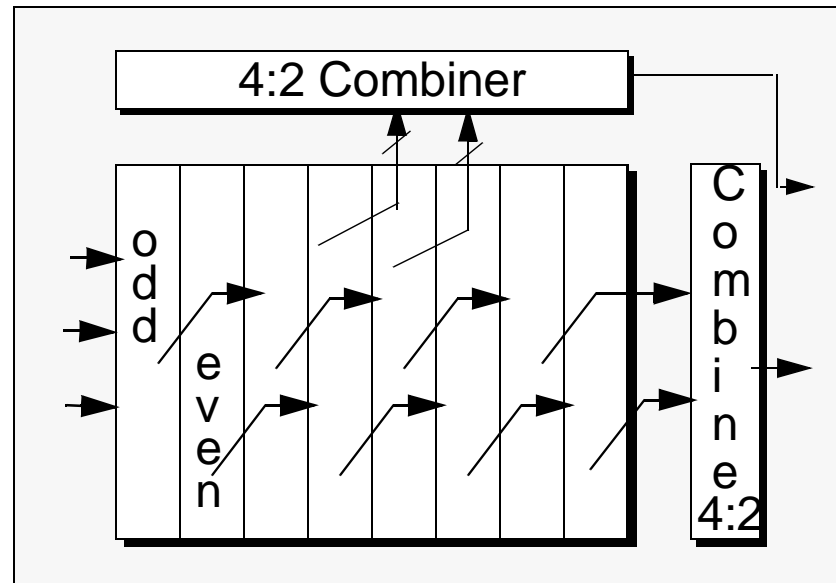

- Full-array critical path reduced by half for small area overhead
- Longer wires within the array
- Can we do even better?

# Array-of-Arrays

---

General Idea:

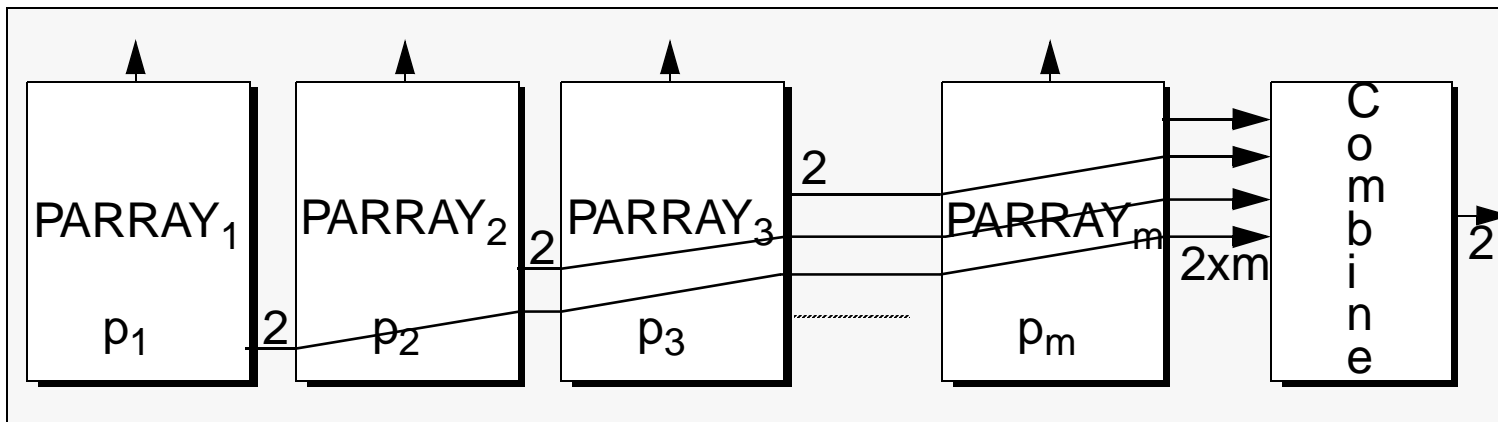

- More partial arrays: higher parallelism, wiring complexity, larger combining network
- Chose  $M$  depending on problem size

# Two Partial Arrays

---

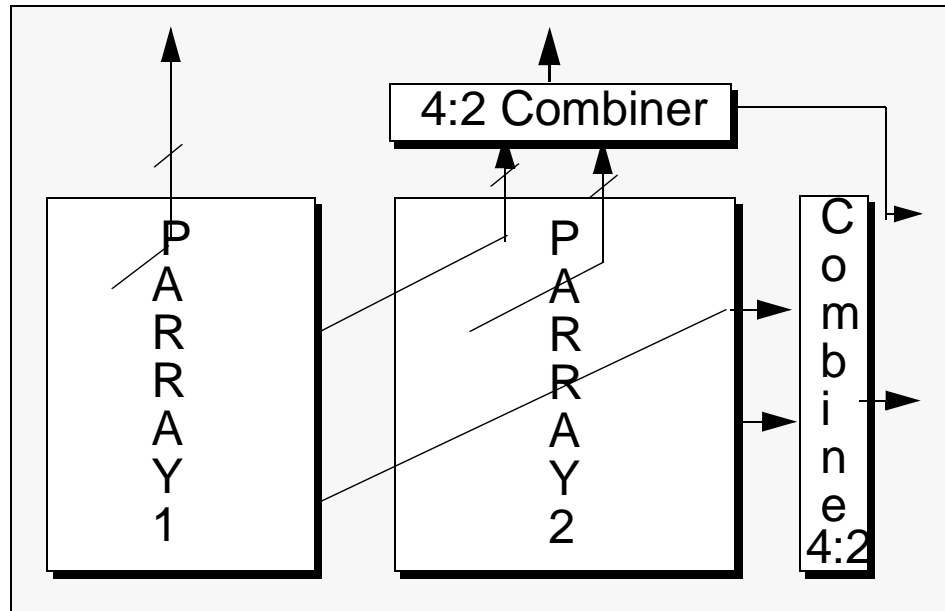

- Regular wiring, small number of cross-overs
- Maximum effective wire loading  $\sim 1.5 \times \text{CSA delays}$
- For optimal parallelism,  $p1=13 + p2=14$ .  
 $\sim 14.5$  CSA delays in critical path

# Four Partial Arrays

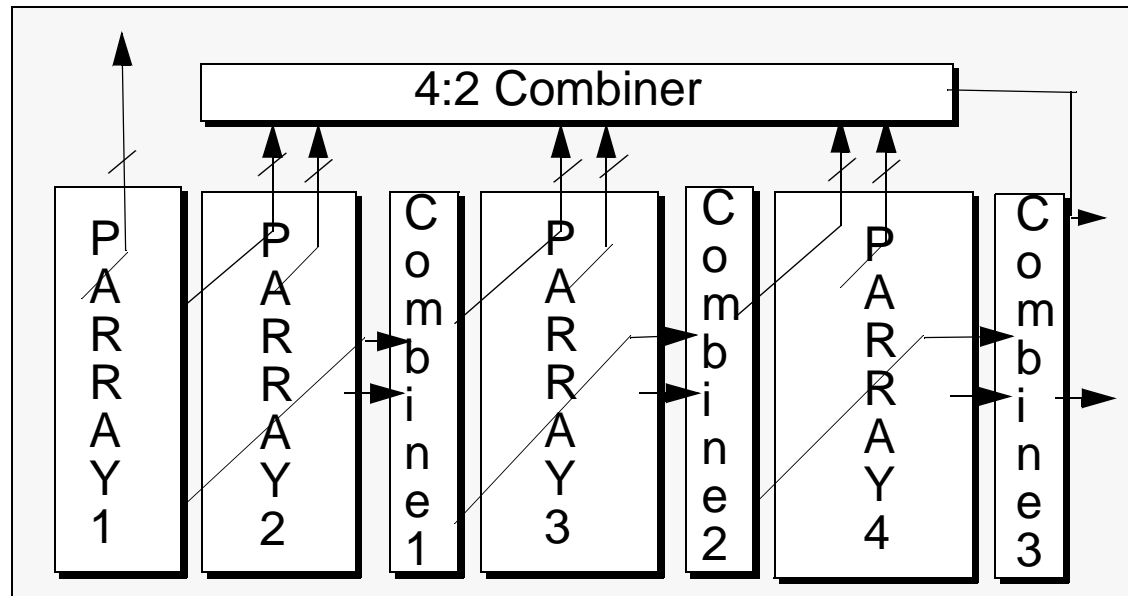

- Tree combiner: Wiring, area overhead
- Matching Array Delays: 5+5+7+10 pp.10 CSAs
- Optimal Parallelism: 4+4+8+11 pp. 11 CSAs
- More Partial arrays?: marginal returns

# Details

---

There are two details that we still need to cover

- Dealing with the bits that fall off the end of the array

In the array organization the datapath width remain constant

The 'extra' (LSB) bits fall off the top of the array

But these bits are still in redundant form

For rounding these bits need to be added too

- Dealing with negative partial products

The problem is with sign extension

Need to extend the sign bits the full  $2N$  bits

This is  $N$  additional bits for the first PP

Look at these issues next

# LSBs Falling Off the Array

Speed through the array is one CSA delay

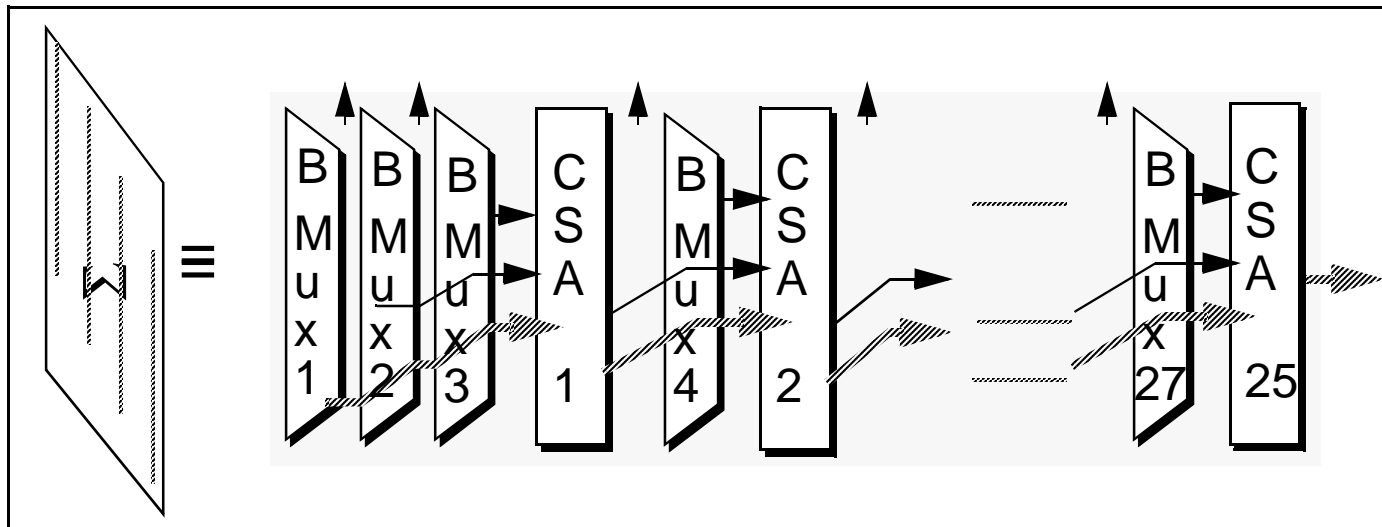

- But since the PP are booth coded, two bit positions fall off each stage
- Need to do a two bit carry propagate add in on CSA delay

Build a small carry select adder

Carry in to carry out is only a mux delay

# Faster Structures

Do more adds in parallel, making dealing with the end bits harder

- In tree adder, all the bits fall off the end at roughly the same time
- Array of arrays has a similar problem

Need to build a complete carry propagate adder for these bits

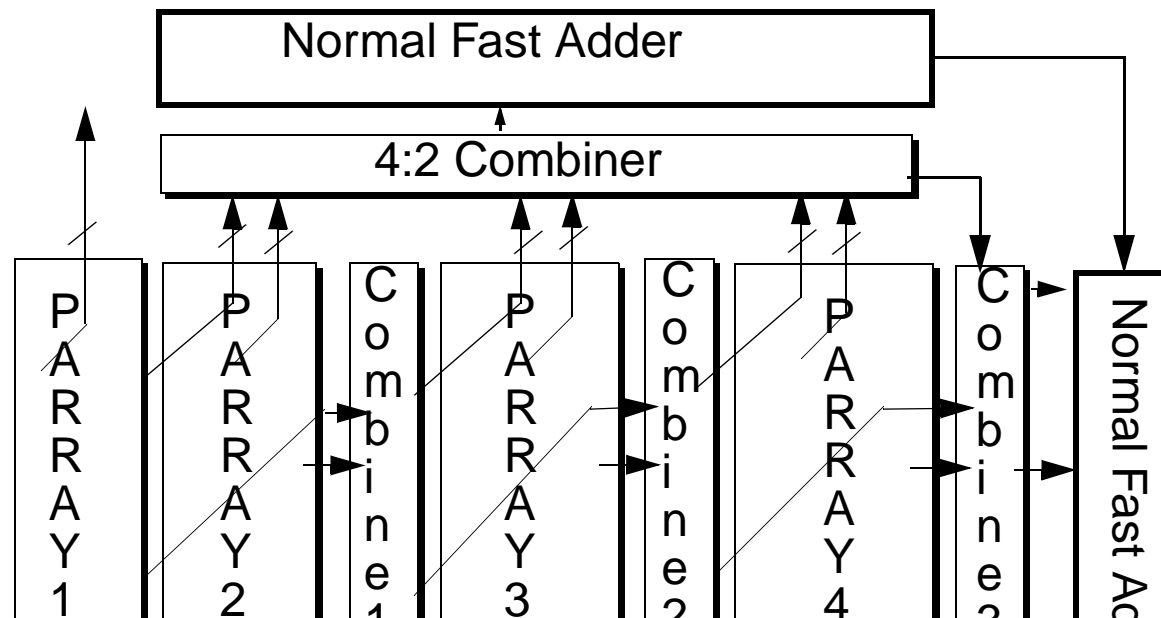

# Sign Extension

---

When the PP is negative, need to sign extend

- This is bad since the fanout can be large

Use a trick instead

- Pre-add the triangle of 1's

$$\begin{array}{cccccccc} 1 & 1 & 1 & 1 & 1 & 1 & 1 & 1 \\ 1 & 1 & 1 & 1 & 1 & 1 & & \\ 1 & 1 & 1 & 1 & & & & \\ 1 & 1 & & & & & & \\ \hline 1 & 0 & 1 & 0 & 1 & 0 & 1 & 1 \end{array}$$

- To clear out 1's add 1 to the row

$$\begin{array}{cccccccc} 1 & 1 & 1 & 1 & 1 & 1 & 1 & 1 \\ & & & & & & & \bar{1} \\ \hline \end{array}$$

# Sign Extension

---

So you only need to add few bits:

$$\begin{array}{cccccccc} & & & & & & \bar{S} & S & S \\ & & & & & 1 & \bar{S} & & \\ & & & & 1 & \bar{S} & & & \\ & & 1 & \bar{S} & & & & & \\ \hline & 1 & 0 & 1 & 0 & 1 & 0 & 1 & 1 \end{array}$$

Adding these bits together is the same as complete sign extension